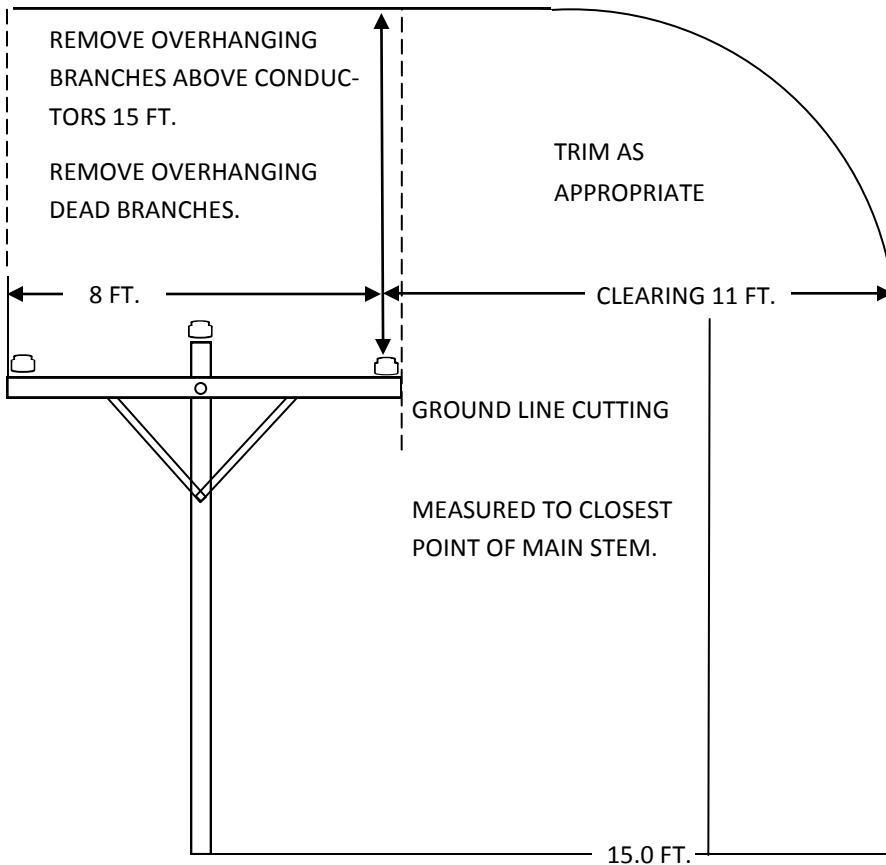

EXHIBIT #1

PRIMARY CLEARING REQUIREMENTS: RURAL SITES & PRIVATE RIGHT-OF-WAY

(RURAL SITES ARE: NOT DEVELOPED DIRECTLY, NOT MAINTAINED, AND ARE OCCUPIED BY NATURALLY OCCURRING PLANTS.)



ALL DISTANCE ARE MEASURED FROM OUTERMOST PRIMARY CONDUCTOR.

CLEARING AND TRIMMING PRACTICES SHOULD BE FOLLOWED.

QUALIFIED LINE CLEARANCE JUDGEMENT ON TREE SHELF REMOVAL & SPECIMEN TREES TO REMAIN ARE TO BE MADE ON AN INDIVIDUAL BASIS.

IF THERE IS TOTAL LOW-GROWTH COVER IN A SECTION OF ROW, THEN CONTRACTOR WILL STILL HAND CUT OR MOW A PATH AT LEAST 5 FEET WIDE TO FACILITATE CREW MOVEMENT THROUGH THE ROW.

A tree outside 15' from center line, not yet causing an outage, should not be cut down until after a documented verbal communication with the member. Pictures of line endangerment would also suffice. In the meantime, only side trim. Trimming more than a third of a tree may place the life of the tree at risk.

☐ = DENOTES PRIMARY CONDUCTOR

Windrow all cut brush at the edge of remaining tree line. Chipping branches will be necessary at contractor's discretion with any future cleanup at contractor's expense. Chip all branches which are within 30' of the road and visible from the road. Do not pile chips! Spread chips along R.O.W.

EXHIBIT #2

PRIMARY CLEARING REQUIREMENTS RESIDENTIAL SITES

(RESIDENTIAL SITES ARE DEVELOPED, MAINTAINED, AND TYPICALLY LANDSCAPED)

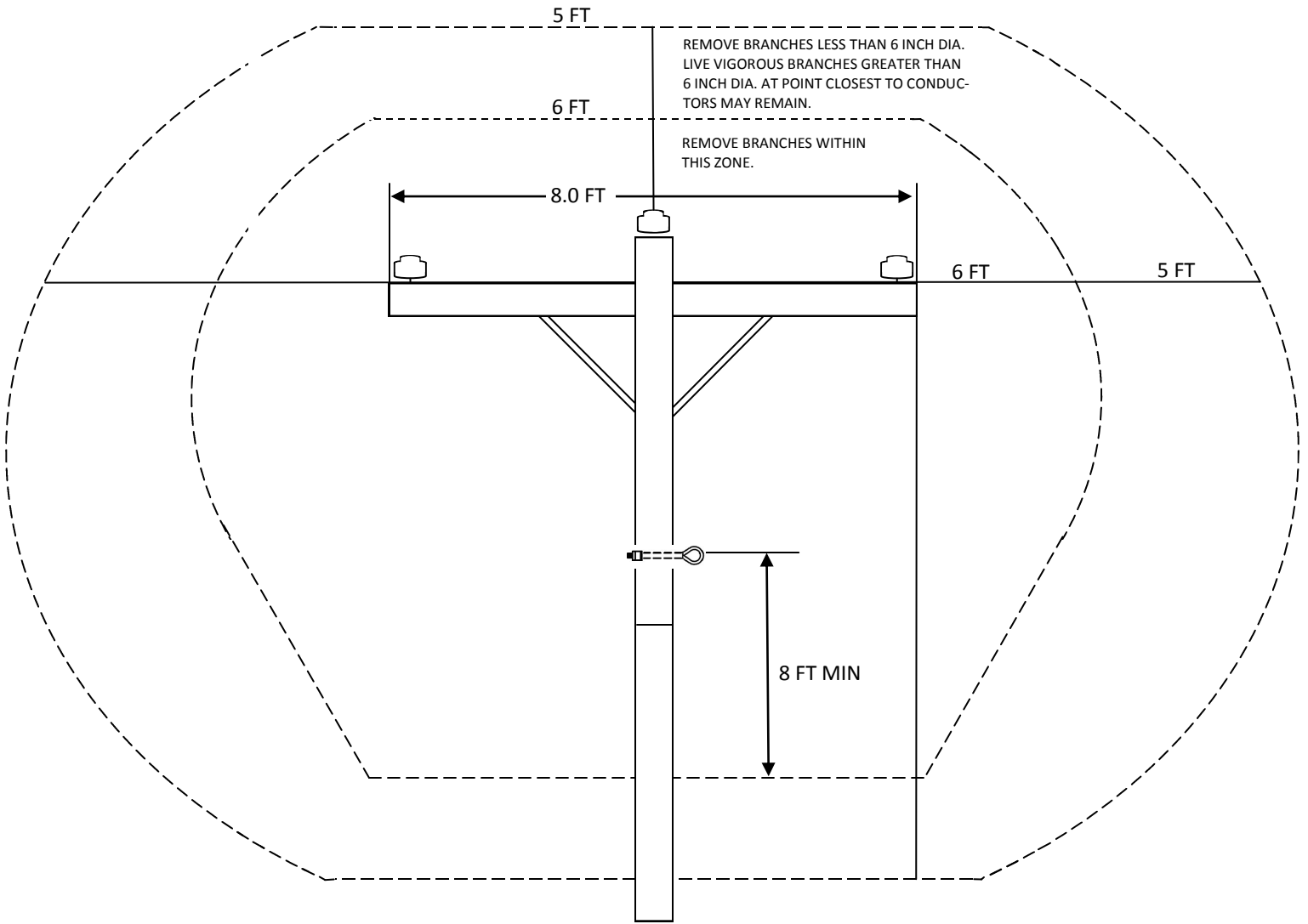

 = DENOTES PRIMARY CONDUCTOR

 = DENOTES NEUTRAL CONDUCTOR

TOP TREES ONLY WHEN LAND OWNER WILL NOT ALLOW REMOVAL.

Chipping branches will be necessary at Contractor's discretion with any future cleanup at Contractor's expense. Chip all brush near landscaped areas. Do not pile chips! Remove chips from landscaped areas and move all 5' - 6' cut trunks and branches to non-landscaped R.O.W. at the edge of remaining tree line.